



**Food Processor
Prep4You cutter mixer 3.6l/3.8qt,1
speed, 750w, nema 5-15p**

ITEM # _____
 MODEL # _____
 NAME # _____
 SIS # _____
 AIA # _____



602249 (DK36US)

Cutter Mixer with 3,6 lt/3.8 qt stainless steel bowl, single speed (1800 rpm), 750W/1HP, NEMA 5-15P plug

Short Form Specification

Item No. _____

Cutter Mixer 3,6lt/3.8 qt., stainless steel bowl with scraper and central feed hole for adding products in mid-cycle. Transparent copolyester lid. Fine serrated blade rotor. Angled blades and conical base of the bowl ensure consistent mixing. All ingredients are processed evenly and quickly thanks to a special flow generated inside the bowl. No-volt release system prevents accidental start of the appliance. All parts in contact with food are removable and dishwasher safe. Watertight, easy to clean, flat, soft-touch buttons. Single speed 1800 rpm with on/pulse/off function for simple operations. With US plug.

Main Features

- Tabletop cutter mixer and emulsifier allowing fast chopping, mixing, mincing, griding, liquidizing and kneading.
- Bowl/lid scraper included for uniform smooth results (emulsifying) and continuous working.
- Transparent lid, with funnel shaped hole, to add ingredients during use.
- All ingredients are processed evenly and quickly thanks to a special movement generated inside the bowl.
- Easy to clean and watertight control panel with on/off button and pulse function.
- Pulse function to coarse chopping.
- All parts in contact with food are removable without the use of tools, completely dismountable and dishwasher safe.
- ErgoCert 4-star certification for ergonomic design and ease of use.
- Productivity up to 50 settings per service.
- Includes 3.8 quart stainless steel bowl with micro-toothed blades rotor.

Construction

- Transparent copolyester bowl
- Microtoothed blades in 420 AISI stainless steel and ergonomic scraper in high resistant composite material to ensure consistent mixing.
- compact design, easy to move and store.
- IPX5 (IP55) flat panel touch-control, watertight panel.
- Main switch ON/OFF on the back of the appliance.
- Asynchronous industrial motor with no brushes for high reliability and quiet functioning, stainless steel motor shaft.
- Food safety assured thanks to BPA-free materials and compliance with NSF standards.
- Product safety in accordance with international and UL standards.
- 1 speed: 1800 rpm.
- Motor power: 1 HP/ 750 Watt.

APPROVAL: _____

Prep4You cutter mixer 3.6l/3.8qt,1 speed, 750w, nema 5-15p Food Processor



Food Processor Prep4You cutter mixer 3.6l/3.8qt,1 speed, 750w, nema 5-15p

Included Accessories

- 1 of Transparent lid without sealing for 3,6lt Cutter Mixer bowl (1 speed models) PNC 650118
- 1 of Fine serrated blade rotor for 3.6lt Cutter Mixer PNC 650233
- 1 of Stainless steel bowl for 3.6lt Cutter Mixer PNC 650235
- 1 of Scraper for 3.6lt Cutter Mixer bowl PNC 650236

Optional Accessories

- Transparent lid for 2,6lt Cutter Mixer bowl PNC 650117
- Transparent lid without sealing for 3,6lt Cutter Mixer bowl (1 speed models) PNC 650118
- Fine serrated blade rotor for 2.6lt Cutter Mixer PNC 650226
- SMOOTH BLADE ROTOR FOR 2.7QT CUTTER MIXER PNC 650227
- Stainless steel bowl for 2,6lt Cutter Mixer PNC 650228
- Transparent copolyester bowl for 2,6lt Cutter Mixer PNC 650229
- Scraper for 2.6lt Cutter Mixer bowl PNC 650230
- Stainless steel bowl for 2,6lt Cutter Mixer, fine serrated rotor, lid with scraper PNC 650231
- Fine serrated blade rotor for 3.6lt Cutter Mixer PNC 650233
- SMOOTH BLADE ROTOR FOR 3.8QT CUTTER MIXER PNC 650234
- Stainless steel bowl for 3.6lt Cutter Mixer PNC 650235
- Scraper for 3.6lt Cutter Mixer bowl PNC 650236
- Transparent bowl for 2,6lt cutter mixer, fine serrated rotor, lid with scraper PNC 650245





Food Processor Prep4You cutter mixer 3.6l/3.8qt, 1 speed, 750w, nema 5-15p

Front

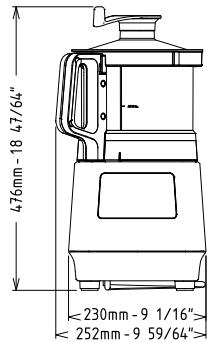

Side

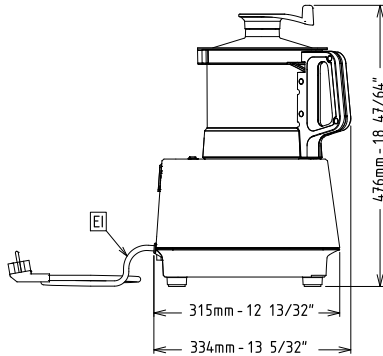

EI = Electrical connection

Top

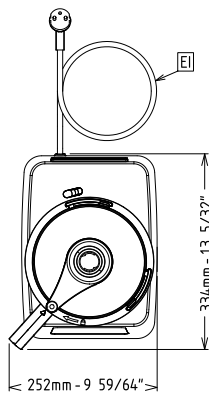

Electric

Supply voltage: 115 V/1N ph/60 Hz
Electrical power, max: 1 kW
Total Watts: 1 kW

Capacity:

Capacity (quarters): 3.8
Capacity: 3.6 Litre

Key Information:

External dimensions, Width: 9 15/16" (252 mm)
External dimensions, Depth: 13 1/8" (334 mm)
External dimensions, Height: 18 3/4" (476 mm)
Shipping weight: 44 lbs (19.9 kg)



Food Processor
Prep4You cutter mixer 3.6l/3.8qt, 1 speed, 750w, nema 5-15p
The company reserves the right to make modifications to the products
without prior notice. All information correct at time of printing.

2026.04.21